

# F0730L (pull type)

## DRAWING (mm)

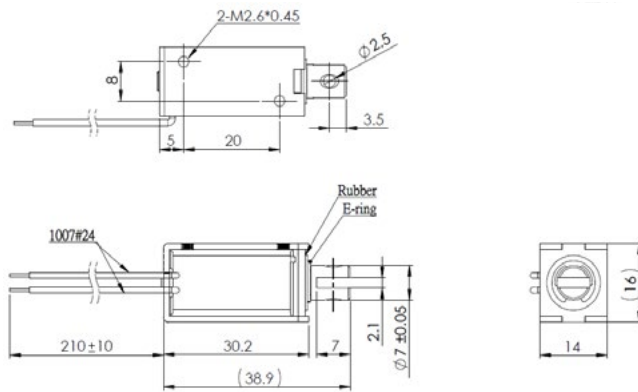

## PHOTO



## MODEL NO. DESIGNATION

F0730L - VOLTAGE  
Example: F0730L-12V

## SOLENOID DATA

Duty cycle / ED (%) ▶	Continuous (100%)	Intermittent (50%)	Intermittent (25%)	Intermittent (10%)	
Watts @ 20°C ▶	2.2	4.4	8.8	22	
Maximum time in energized state (in seconds) ▶	∞	55	19	3	
Part ▼	Resistance (20°C) ± 10% (Ω) ▼	DC Volts (V) ▼			
F0730L-06V	16.4	6	8.5	12	19
F0730L-12V	65.5	12	17	24	38
F0730L-24V	262	24	34	48	76

## SOLENOID FEATURES AND STANDARD DATA

	STANDARD	CUSTOMIZATION OPTIONS
Type	Pull type DC solenoid	Push type DC solenoid
Cable	Flying wire 230mm	Length, type and connector
Voltage	6 to 24 VDC @ 100% ED	Other voltages upon request
Life time	At least 500.000 single strokes	
Plunger material	Carbon steel 12L14	
Protection class	IP00	
Insulation grade	B	
Operating temperature	-5°C ... +40°C	
Manufacturing quality standards	ISO9001:2008, ISO/TS 16949:2002	
RoHS compliance	Yes	
CE approval	No	
UL approval	No	

## ADDITIONAL DATA

Return spring	Yes
Weight	33g

## SPRING DATA

Loading force @ 1mm compression	93 ± 5g
---------------------------------	---------

## PLUNGER PROFILE



## DIAGRAM

